

S-BOX™ CHAMELEON



INTERNATIONAL POP-UP SOCKETS



WITH CAMOUFLAGE SKILLS



S-Box® Chameleon ‘pop-up’ sockets are very special.

Their patented ‘instant lift’ action delivers power points quickly, and beautifully, by the simple press of a finger, with no motor, no springs, and no gas struts to do so, and are cleverly designed to use the project material as their custom top.



It is, at last, now possible to provide countertop power that is camouflaged in its surroundings . . . until it is actually required!

S-Box™ products are nothing like the plastic towers of the past. They are tough, stylish and discreet, and are built from solid steel.

**IN NATURE, CAMOUFLAGE IS A MATTER OF SURVIVAL
IN DESIGN, IT’S A MATTER OF STYLE!**



S-Box® Chameleon pop-up sockets are manufactured in a wide range of International Plug Types and are used by Designers in over 70 Countries around the world.

The S-Box™ socket box design has passed the ½ gallon Countertop Spill and Splash Tests for use in Wet Areas, so it is both a stylish and safe solution for providing convenient power in any work-surface or kitchen island.



NEC 2.2 litre (½ Gallon) Saline Liquid Spill Test 406.5 (E)





WORLD SOCKET OPTIONS

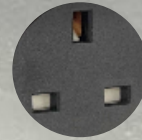

GB/IRE (Type G)



EURO Schuko (Type F)



FR/BE/CZ/PL (Type E)



ITALY (Type L)



SWITZERLAND (Type J)

Water Jet cutting technology now allows S-Box™ units to be “book-matched” for full Chameleon camouflage.

Cutting by Router will have to be a “best match”. (see page 9)

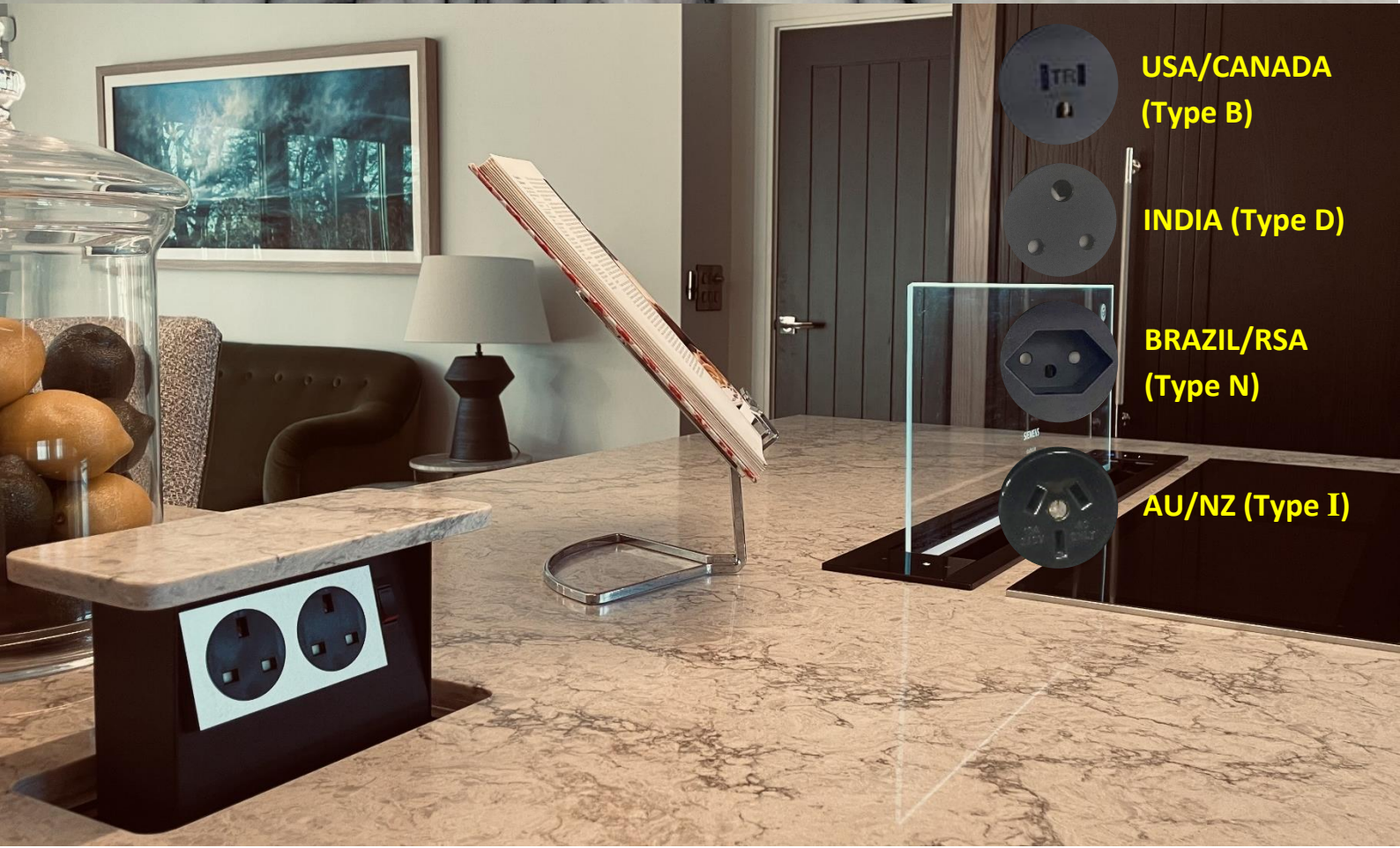

USA/CANADA (Type B)



INDIA (Type D)



BRAZIL/RSA (Type N)



AU/NZ (Type I)

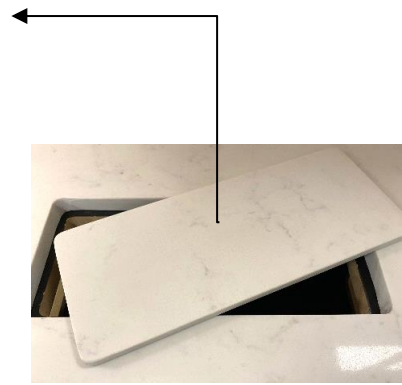
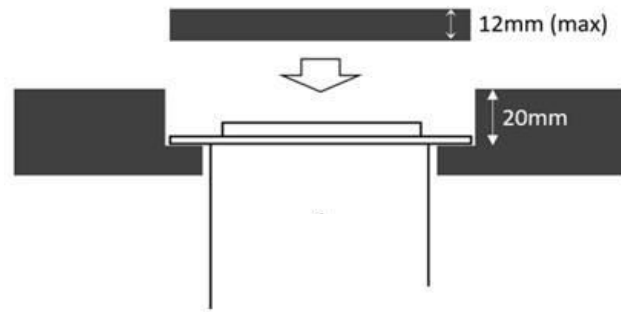

- .. NO MOTOR
- .. NO SPRINGS
- .. NO GAS STRUTS

A "zero-energy" lift system that *adjusts* for different weight!

S-Box® Chameleon uses a **10-12mm piece of your work-top material** to create a camouflaged finish, and **sits on a rebate 20mm below surface.**

The patented "press and lift-action" still pops-up automatically
 .. whatever density of material is being used for the Top!



This is the engineering break-through that designers have been waiting for!
 A simple adaptable 'lift-system' for **any** material . . . from lightweight timber through to heavy-weight granite and quartz!

It is now possible to provide convenient countertop power without spoiling the clean lines of any design, or the beauty of a surface finish.





S-BOX™ 2012-2024

S-Box™ USB-C modules feature IDR (Intelligent Device Recognition)

“NEXT GENERATION” USB TECHNOLOGY

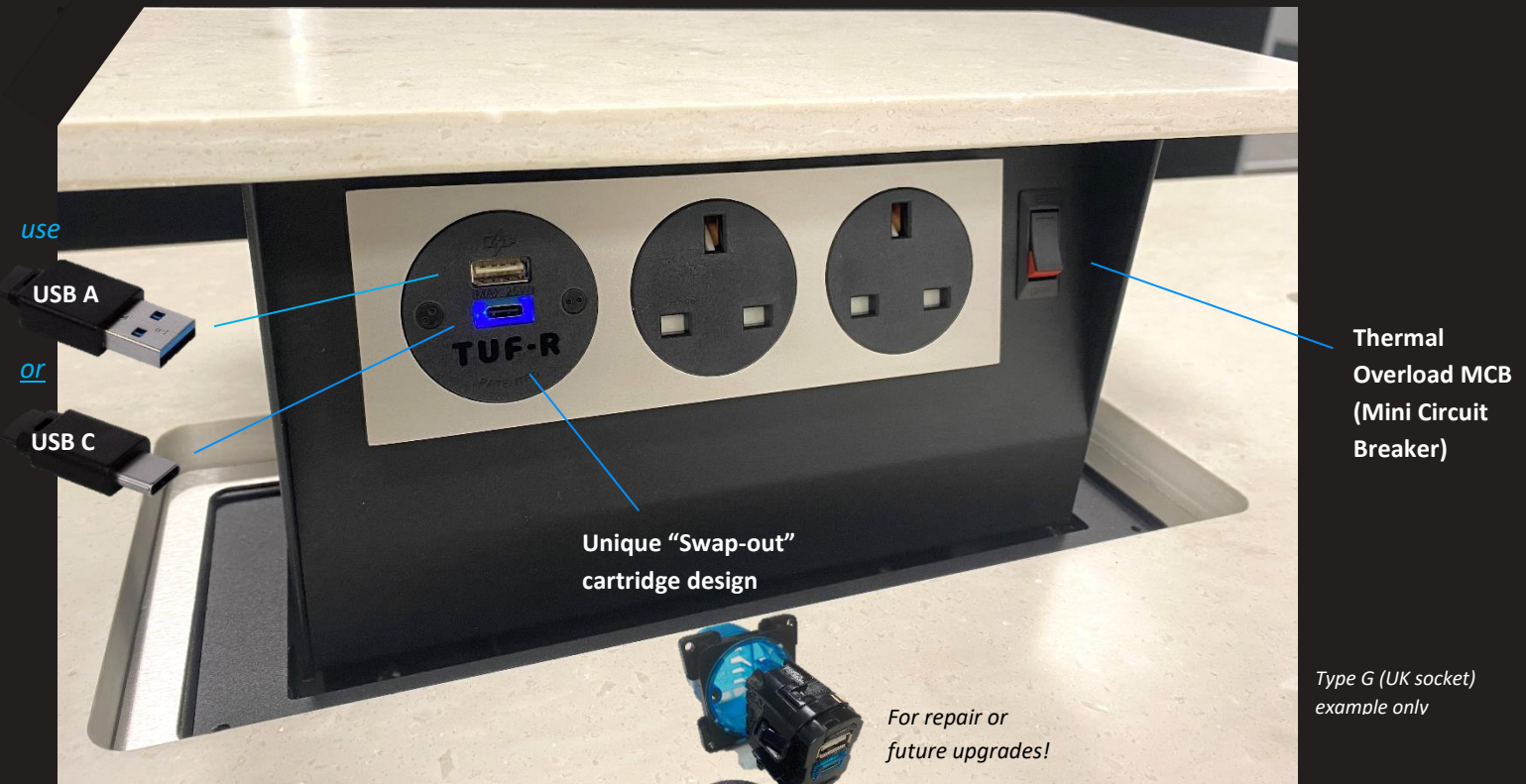

25 Watts of ‘clever’ power

for Mobile Phones

The TUF-R® A+C USB charger offers different supply voltages depending on the device being charged. This is Intelligent Device Recognition (IDR) – with a TOTAL of 25W available.

When a device is plugged in to either Type A or Type C socket a digital ‘handshake’ takes place allowing the TUF to charge the device at the optimum level – automatically!

USB - C 5 Volts x 3 Amps = 15 Watts
9 Volts x 2.22 Amps = 20 Watts
15 volts x 1.65 Amps = 25 Watts
20 Volts x 1.2 Amps = 24 Watts

USB - A 5 Volts x 3 Amps = 15 Watts
9 Volts x 2 Amps = 18 Watts
12 volts x 1.5 Amps = 18 Watts

or **‘COMMERCIAL GRADE’ OPTION**
WITH ULTRA-HIGH POWER USB of 72 WATTS!
For Laptop/Tablet/MacBook® & Office



Provides: 12W to USB-A
60W to USB-C



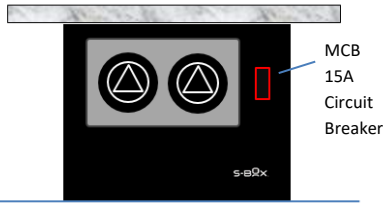

MCB
15A
Circuit
Breaker

2-PORT MINI

Available in **two** alternative models:

← **2 x Sockets only**

OR **1 x Socket + USB 25W** →



USB25

Code: **CHAM-MINI** - (+ socket type)

Code: **CHAM-MINI-25W**- (+ socket type)

STANDARD 25 Watt USB-C
for Mobile Phones

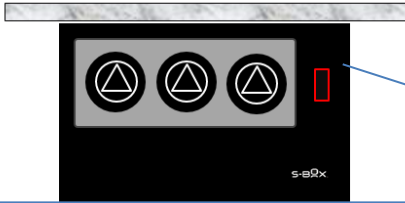

3-PORT (3 x Sockets)

Please note that circuit breaker limit is 3,450 Watts (230v x 15A). Total load across all three sockets is 3.46KW.

Code: **CHAM-01** - (+ socket type)

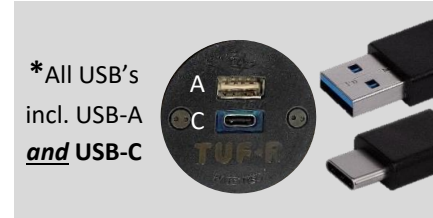

3-PORT (2 x Sockets + USB-C)

Available in **two** alternative models:

← **USB 25 Watts**

for Mobile Phones

OR

USB 72 Watts

with extra power for
Tablet/Laptop



USB25

USB72

Code: **CHAM-02-25W**- (+ socket type)

Code: **CHAM-02-72W**- (+ socket type)

INTERNATIONAL SOCKET TYPES AVAILABLE



TYPE G
BRITISH
STANDARD

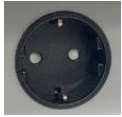

TYPE F
EURO
SCHUKO



TYPE E
FR/BE
PL/CZ



TYPE L
ITALY



TYPE J
SWISS



TYPE B
US15a
120v only



TYPE I
AU/NZ
(3-Socket product only)



TYPE N
RSA / BRAZIL
16A 10A

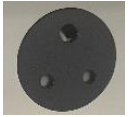

TYPE D
INDIA

All products are manufactured as complete, sealed and tested units with a 2.4m cable tail for connection to mains power by qualified electrician (by 3-pin plug or direct to mains spur, according to local IEC regs)

S-BOX™ CHAMELEON – COMMERCIAL RANGE - with OFFICE “COMMS”

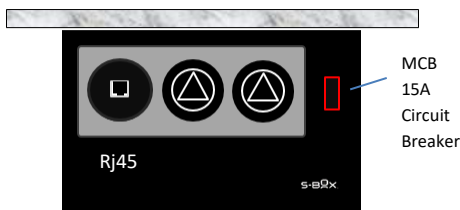

MCB
15A
Circuit
Breaker

Rj45

Code: **CHAM-03**

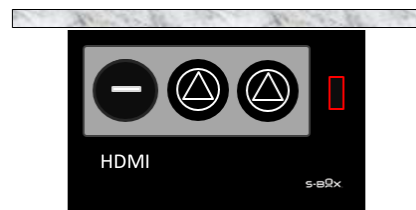

HDMI

Code: **CHAM-04**



Rj45 HDMI

Code: **CHAM-05**

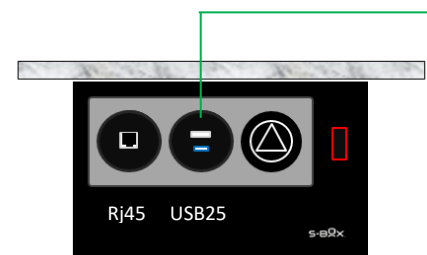

Rj45 USB25

Code: **CHAM-06-25W***

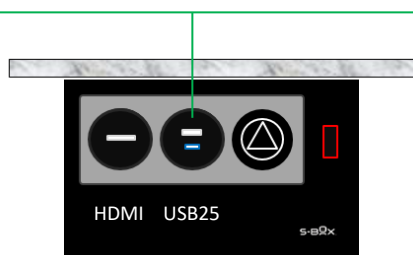

HDMI USB25

Code: **CHAM-07-25W***

*For Ultra-high-power
USB (72W) option

use
Code: **-72W**





S-BOX™

CHAMELEON





WORKING FROM OFFICE OR WORKING FROM HOME?

WE HAVE THE POWER AND 'COMMS' TO DELIVER WHAT YOU NEED



HDMI



RJ45



USB-TUF 25W
(MOBILE PHONES)



USB-HP- 72W
(MOBILES and Tablets and LAPTOPS etc)



THE WORKTOP - RULES 1 & 2

- 1** S-BOX® CHAMELEON MODELS are supplied **without a top**, and are designed to drop into a pre-cut hole in the Counter **on a rebate at exactly 20mm below the surface** i.e. a 'shelf' of material.
- 2** They are duly ready to receive their own matching piece of worktop (up to 12mm maximum thickness) to be used as the custom top.

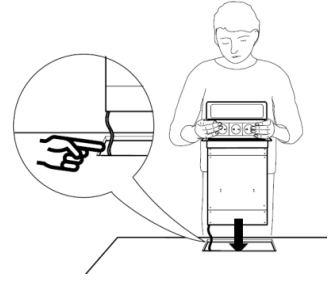

CUTTING OF STONE MATERIALS SUCH AS GRANITE & QUARTZ IS A **FACTORY PROCESS** SO PLEASE INVOLVE THE FABRICATOR OF SUCH MATERIALS IN THE DESIGN & SPECIFICATION PROCESS

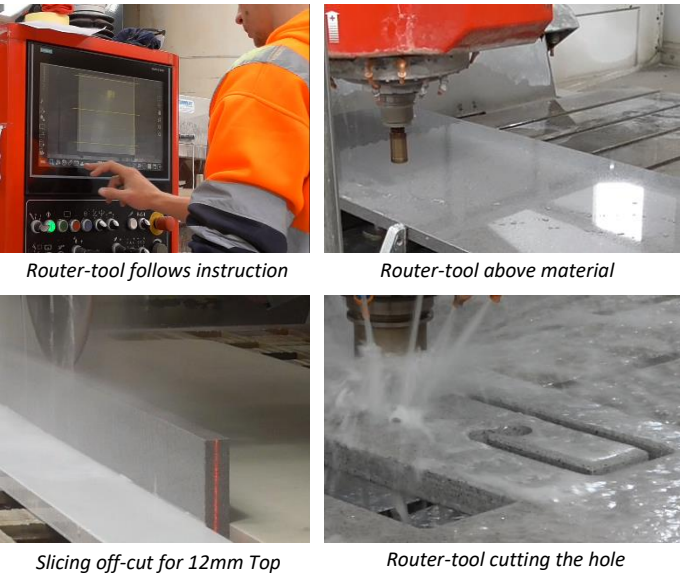
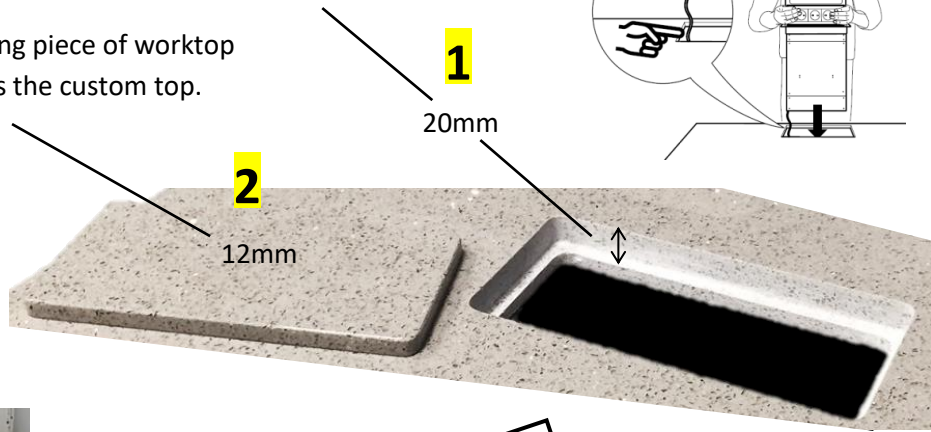

This rebate is either a **"True Rebate"** - e.g. one that is pre-cut by a router **within thick material (30mm and over)**

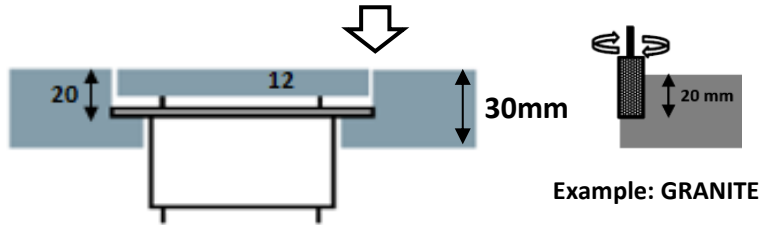

OR it is a **"False rebate"**. This is one that is *created* directly below thinner material (20mm or less) by using a **secondary material bonded underneath** to 'create' the shelf.

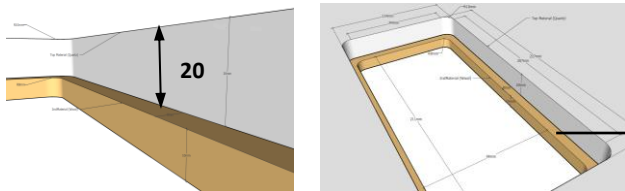
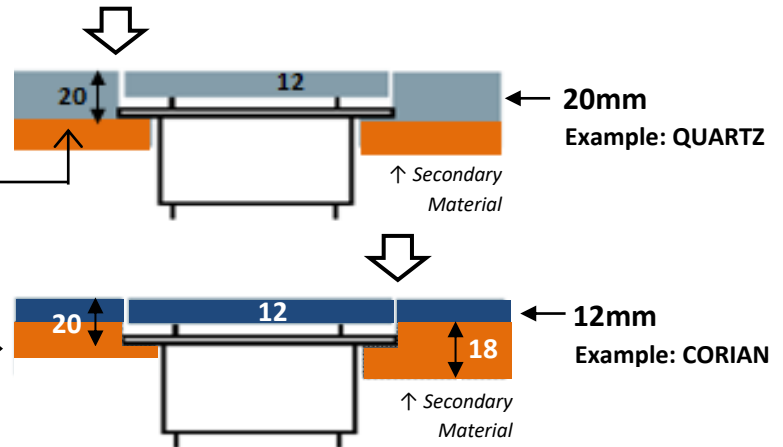

CLICK THIS LINK

FOR FULL INSTRUCTIONS + CUTTING DIMENSIONS >> <https://www.the-sbox.com/tech-data/>

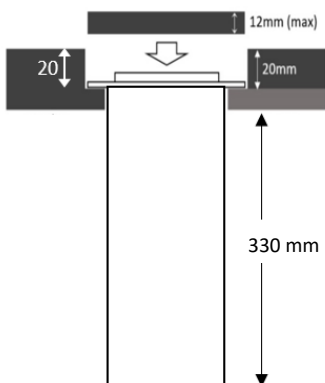

2-PORT MINI

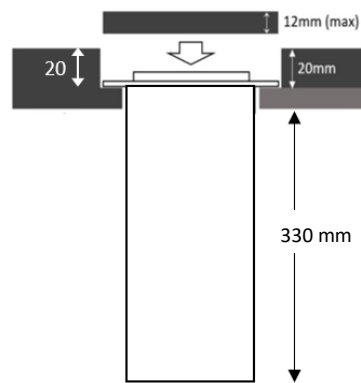

3-PORT

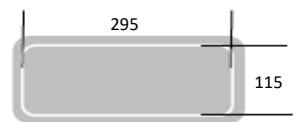

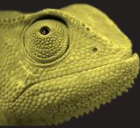

S-BOX™

A British Design Innovation 

Cardinal Innovations Ltd, Battye Street, Bradford, West Yorkshire, ENGLAND BD4 8AG

Tel: +44 (0) 1274 386820 Email: sales@the-sbox.com Website: www.the-sbox.com

S-Box™ is a Registered Trademark

The S-Box™ pop-up action and camouflage feature are protected by International Patents in UK, EU, USA, CANADA, AU & ASIA.